

HERBOLD

Granulators SMS Series

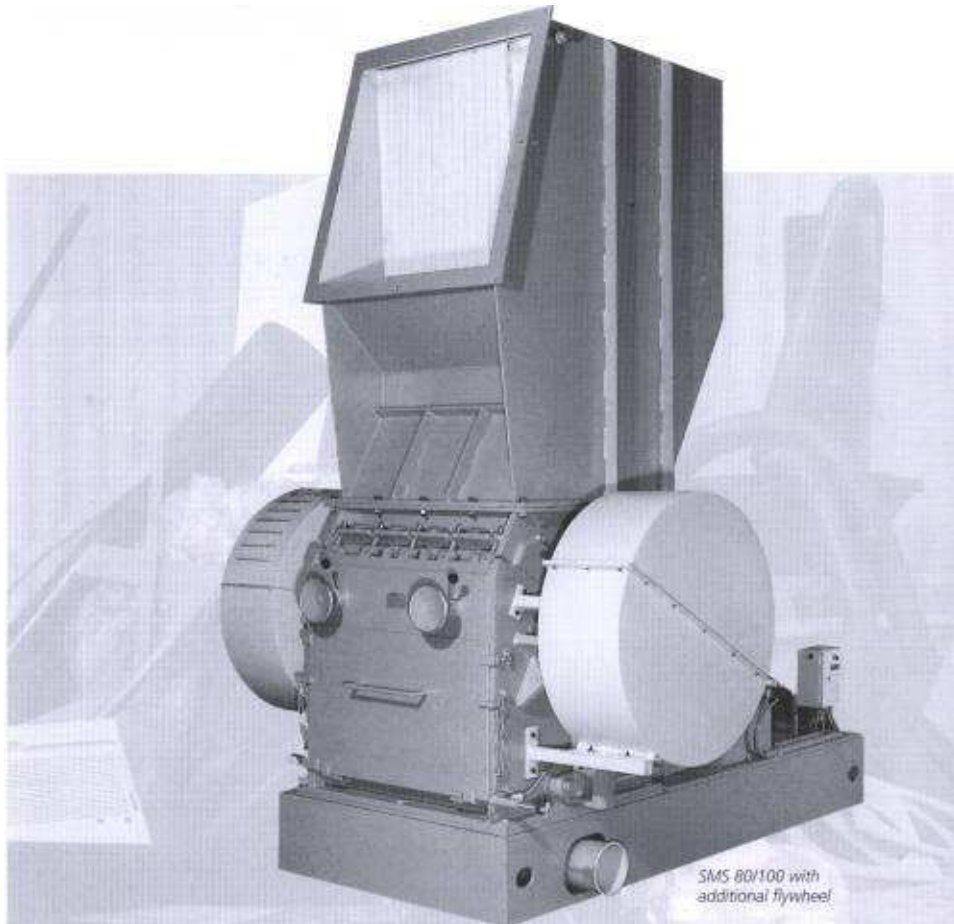

SMS 80/100 with additional flywheel

- heavy-duty knife granulator for tough application
- multiple applications by removable deflection wedge
- energy-efficient double-cross cutting action
- constant cutting circle due to adjustable rotor and bed knives
- optimum access to the cutting chamber for ease of cleaning and maintenance

Universal application range of the SMS series

The deflection wedge is an insert with a 3rd bed knife that can be installed or removed quickly, extending the range of applications.

Without the deflection wedge the feed opening is wider and allows size reduction of large bulky parts. With the deflection wedge fitted, heavy lumps, thick-walled pipes, thick sheets, and other massive articles can be processed. The deflection wedge prevents the rotor from being over-aggressive.

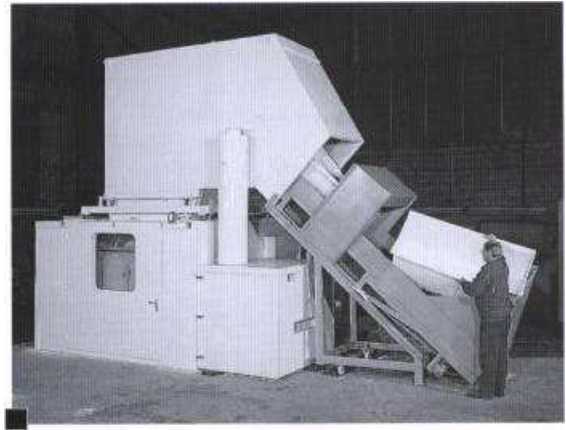

SMS 80/100 without deflection wedge for refrigerator housings

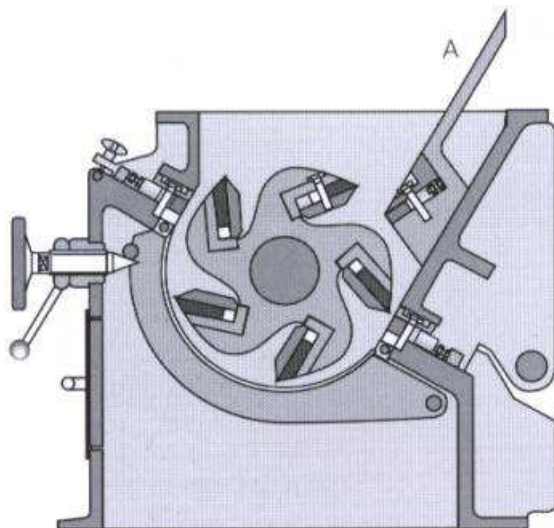

cross section of cutting chamber with deflection wedge (A) for massive pieces

The SMS series has the same advantages that all Herbold granulators have

- sturdy welded steel construction
- housing divided at an inclined angle
- outboard mounted bearings
- rotor and bed knives are adjusted outside of the granulator
- constant cutting circle due to adjustable knives
- compact and space-saving design

Knife adjustment outside of the granulator

The rotor and bed knives are adjusted in a fixture outside of the granulator. This process will reduce downtime and ensure that the distance from the cutting edge of the knife to the screen is maintained. With this feature your throughput will not change even with last knife sharpening.

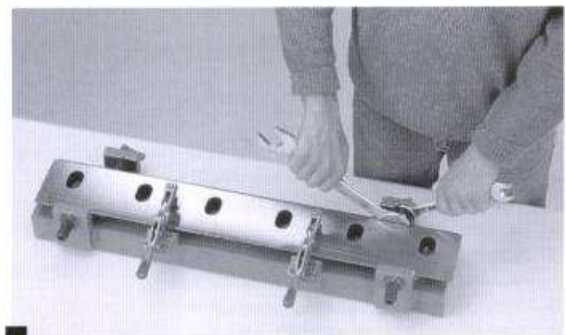

Knife adjustment fixture

Optimum access to the cutting chamber and screen for easy cleaning and maintenance

For cleaning and maintenance purposes the granulator can be opened very quickly. The upper section of the housing with the hopper is opened giving optimum access to the cutting chamber. The screen is removed through the maintenance door in the front of the cutting chamber. Easy and quick cleaning (e.g. color or product changes) is a standard feature of the Herbold granulators.

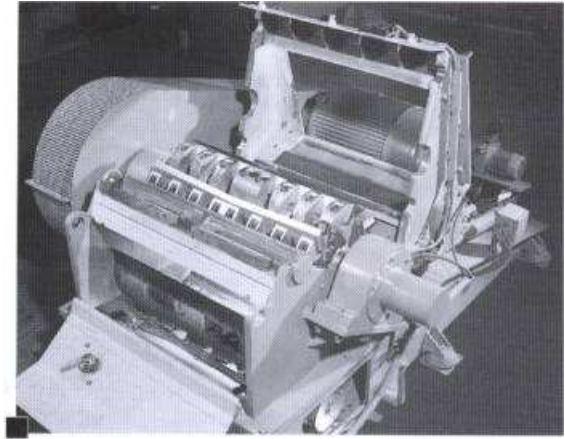

*SMS 56/100
fully accessible cutting chamber*

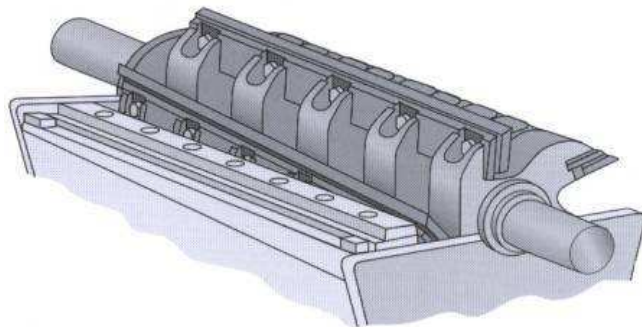

*conventional double
cross cutting geometry*

Double cross cutting action and external rotor bearings

The rotor and bed knives are mounted in the same but opposite angle to ensure a steady cutting gap across the full length of the knife. Thus, the power requirement is reduced, the inertia is increased, and the quality of the regrind is improved - it contains less fines and its bulk density is higher!

The rotor bearings of all Herbold granulators are located in outside steel pillow blocks: no material gets into the bearings, no grease gets into the product.

From a rotor width of 1000 mm upwards you can also opt for the double cross cutting with the chevron-shaped cutting geometry. With this knife arrangement the material is transported to the middle of the rotor and kept away from the side walls. Wear at the side wall is reduced. The plastification of heat-sensitive products is avoided.

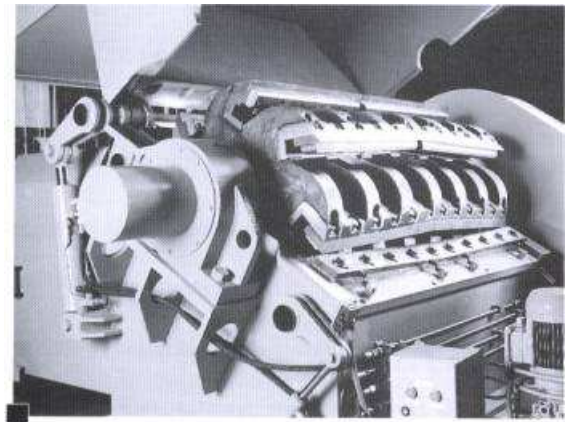

*Double cross cutting by
chevron-shaped knife arrangement*

Granulators and complete systems built to customer specifications

Range of the SMS series

Type	Feed opening* mm, inches	Rotor-Ø mm, inches	Weight** kg, lb	Capacity*** kg/h, lb/hr	Drive kW, HP
SMS 30/30	500 x 290 19.5 x 11.5	300 12	1400 3085	150-200 440-880	11-37 15-50
SMS 30/50	500 x 490 19.5 x 19	300 12	1800 3970	200-400 440-880	11-37 15-50
SMS 30/80	500 x 790 19.5 x 31	300 12	2100 4630	250-500 550-1100	11-37 15-50
SMS 45/60	600 x 578 23.5 x 22.5	450 17.5	3000 6600	400-1200 880-2645	37-90 50-125
SMS 45/100	600 x 980 23.5 x 38.5	450 17.5	4800 10580	600-1500 1320-3300	45-90 60-125
SMS 45/120	600 x 1154 23.5 x 45	450 17.5	6000 13230	750-1800 1650-3970	45-90 60-125
SMS 45/160	600 x 1555 23.5 x 61	450 17.5	6400 14110	900-2000 1980-4400	45-90 60-125
SMS 56/100	720 x 980 28 x 38.5	560 22.5	5000 11020	1000-2800 2200-6170	55-132 74-180
SMS 60/60	720 x 580 28 x 22.5	600 23.5	3000 6600	600-1500 1320-3300	55-132 74-180
SMS 60/80	720 x 780 28 x 30.5	600 23.5	4100 9040	800-2000 1760-4400	55-132 74-180
SMS 60/100	720 x 980 28 x 38.5	600 23.5	5000 11020	1000-2800 2200-6170	55-132 74-180
SMS 80/100	940 x 980 36.5 x 38.5	800 31.5	8000 17640	1500-4000 3300-8800	75-160 100-125
SMS 80/120	940 x 1154 36.5 x 45	800 31.5	9000 19840	2000-5000 4400-11000	75-200 100-270
SMS 80/145	940 x 1450 36.5 x 58	800 31.5	10000 22030	2000-6000 440-13200	75-160 100-215
SMS 80/160	940 x 1555 36.5 x 61	800 31.5	11000 24250	2500-7000 5500-15400	90-250 125-340
SMS 80/200	940 x 1960 36.5 x 77	800 31.5	15000 33070	3000-8000 6600-17600	90-315 125-430
	*flange section on the upper part of the housing		**standard model	*** dependent on the screen hole size and feed material	

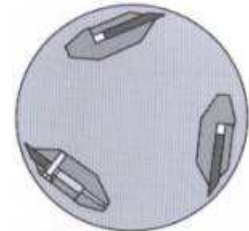

*Special rotor G3 for
heat-sensitive materials*



*Special rotor B3
for hot-melt grinding*

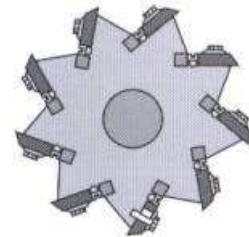

*Special rotor F9 for
high throughput*

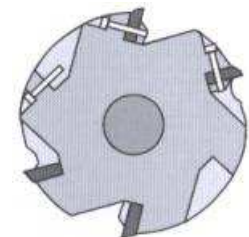

*Special rotor A with a
variable knife configuration*

The boldfaced models are manufactured as standard units and are available at short notice. All other types are made to order. Intermediate sizes can be supplied after agreement.

Special rotors are available for different kinds of material

Optional equipment

To incorporate Herbold granulators into automatic production lines and processes there is a large number of options available as well as special versions:

- electronic metal separation and magnetic units
- air extractors and screening machines
- amperage overload cut-out
- pneumatic and mechanical loading units for feeding the machine or for the removal of the finished granulate
- precrushing units
- pulverizers for fine particle size
- storage silos before and after the granulator
- conveyor belts and feed rolls for sheeting, edge trims and webbing.

Specifications are not binding and subject to change without notice.

Our product range

- Granulators
- Pulverizing systems
- Shredders
- Hammer mills
- Guillotines
- Plastcompactors
- Complete washing systems

Our US-subsiary:

Herbold Meckesheim USA
Resource Recycling Systems Inc.
333 George Washington Highway,
Smithfield Rhode Island 02917

Phone: +1 401-232-3354
or +1 888-612-7774

Fax: +1 401 232 5425

E-Mail: Info@HerboldUSA.net

Internet: www.HerboldUSA.net



Herbold Meckesheim GmbH

Industriestrasse 33
D-74909 Meckesheim / Germany

P.O. Box 1218
D-74908 Meckesheim / Germany

Phone: +49 (0) 62 26 / 932-0
Fax: +49 (0) 62 26 / 932-495

E-Mail: Herbold@Herbold.com

Internet: www.Herbold.com